

# Full HD AMOLED Current-Programmed Driving with Negative Capacitance Circuit Technology

**Reiji Hattori, Chang-Hoon Shim**

Dept. of Electronics, Kyushu University, Motooka, Nishi-ku, Fukuoka 819-0395, Japan

TEL:81-92-802-3731, e-mail: hattori@ed.kyushu-u.ac.jp

**Keywords : AMOLED, Current-Program, Negative Capacitance, Full HD**

## Abstract

*The circuit simulation has been done on the current-programmed AMOLED and shows that the circuit which behaves as a negative capacitance can reduce the effect of parasitic capacitance fixed on the data-line and can accelerate the current programming speed as high as that required in Full HD AMOLED.*

## 1. Introduction

Many kinds of driving methods to compensate the AMOLED brightness non-uniformity originated from the TFT characteristic variation have been presented so far. Current-programmed pixel compensation is the most optimal method among them since the all variations in the TFT characteristics including threshold voltage and mobility can be canceled without memory. This fact also supports to improve the fabrication yield of a backplane panel. In addition, this compensation method is free from the cross talk effect due to the voltage drop on a power source bus-line and the sticking image effect due to the temperature rise of TFT. However, this driving method is not used in commercialized products at present because it has the following two serious problems.

The first is a long programming time especially in a dark level. The programming current at the dark level is usually less than 100nA and the parasitic capacitance fixed the data-line is greater than 10pF even in a small sized panel. Therefore, to charge up the data-line capacitance of 10pF by 1V with a constant current of 100nA takes more than 100 $\mu$ sec that is much longer than the selecting time of VGA panel driven in 60Hz frame rate.

The second problem is a high cost of the data driver LSI which must provide a constant current. The current DAC circuit usually needs a large area comparing with the voltage DAC. In addition, the transistors used in the current DAC are large in number and the indi-

vidual transistor size is also large because of the high voltage use.

There have been presented various methods so far in order to shorten the programming time. The pixel circuits using a conventional current-mirror circuit [1] and a series current-mirror circuit [2] were proposed to enlarge the input data-current keeping the OLED current level. The larger input current helps to charge up the parasitic capacitance on the data-line quickly, but the characteristic mismatch between the TFTs consisting of the mirror circuit causes the non-uniformity of brightness. The reduction of the gate voltage in the driving TFT by boost voltage with the scanning line [3] is another effective way, but too much usage of this effect leads the influence of mobility variation. Resetting the data-line voltage at the beginning of the selecting period [4] is an easy and effective way to eliminate the image tailing, but the gradation in some dark levels can not be shown. The voltage [5] and current [6] feedback methods can accelerate the programming speed, but the feedback bus-lines need additionally the same number of connections as that of the data-inputs resulting in doubling the number of column-line connections.

The differentiator feedback method using the second generation current conveyor (CCII) circuit in the data driver LSI [7] is very attractive because the extra bus-lines for feedback are not necessary. However, this method needs a huge capacitance on each output circuit in LSI. The capacitance value must be almost the same as that of parasitic capacitance on the data-line which usually exceeds the 10pF. Such a huge capacitance is impossible to implement in LSI.

We have presented the circuit to achieve the differentiator feedback using a negative capacitance circuit, which can be feasibly implemented into a driver LSI [8, 9]. In this paper, we described the simulation results including the panel circuit with the parasitic ca-

capacitance and resistance on the data-line and discussed the possibility of a full HD AMOLED driven by the current-programmed driving method.

### 2. Current-programmed pixel circuit

Figure 1 shows the examples of current-programmed pixel circuit consisting of three n-channel TFTs and one capacitor (3T1C). These configurations are the simplest of all current-programmed pixel circuits which have ever been presented. The pixel circuit in Fig. 1(a) was employed practically in AMOLED panel using a-Si TFT [4]. The details of this driving scheme were described in the ref. [10]. The difference between them is the OLED connection to TFT. Figures 1(a) and (b) show an anode-connected configuration and a cathode-connected, respectively. According to this difference, the current-sink and source drivers are needed, respectively.

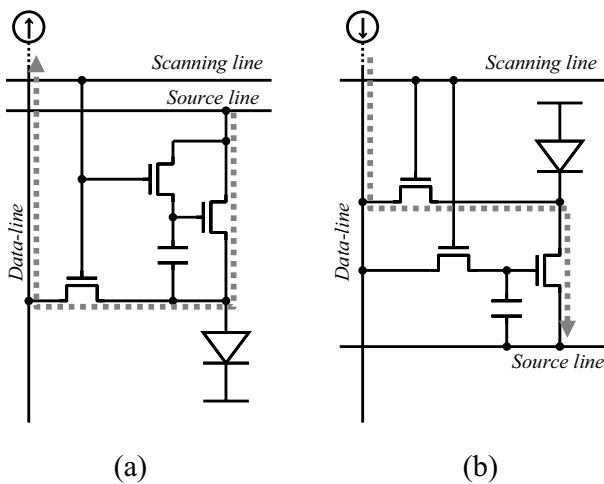

**Fig. 1. Current-programmed pixel circuits using n-channel TFTs. (a) current-sink and (b) current-source configurations.**

Figures 2(a) and (b) show the case using p-channel TFTs. Both pixel circuit configurations also need current-sink and source drivers, respectively.

Therefore, the current-programmed AMOLED needs a current-source or sink data-driver depending on the pixel configuration as stated above. The current level required by a 30-inch full HD panel is about 10 $\mu$ A in maximum to light OLED at luminance of 600Cd/m<sup>2</sup>. Notice that the gate and drain of the driving TFT are connected in a programming period in all configurations, which is true of all the other current-programmed pixel circuit.

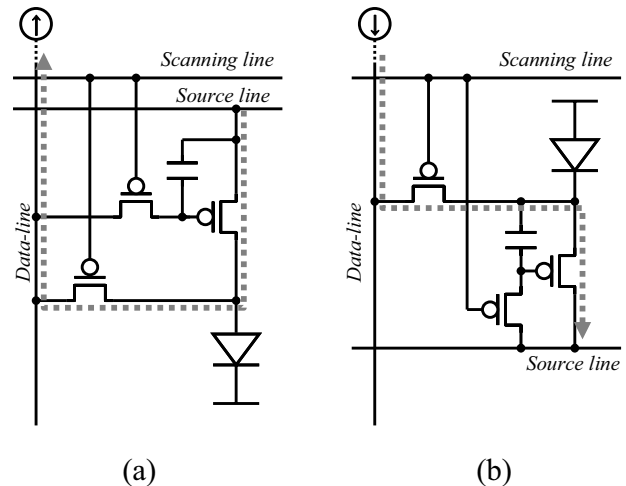

**Fig. 2. Current-programmed pixel circuits using p-channel TFTs. (a) current-sink and (b) current-source configurations.**

### 3. Negative capacitance circuit

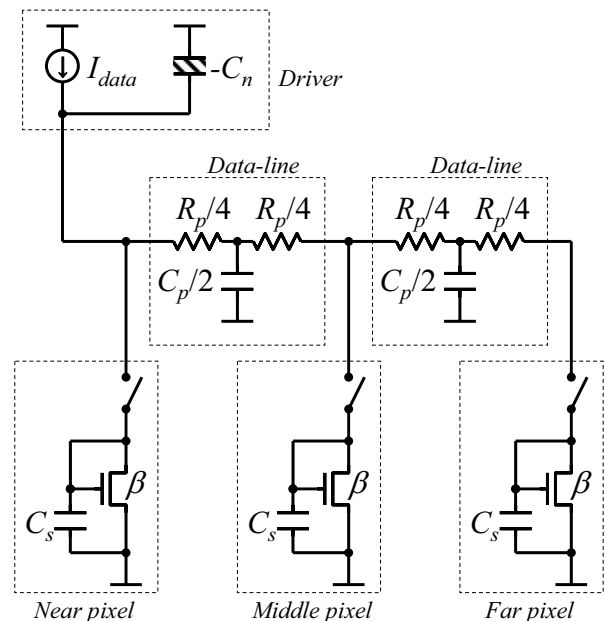

**Fig. 3. Equivalent circuit for current-programmed AMOLED panel and current-source data-driver.**

Figure 3 shows the equivalent circuit of current-programmed AMOLED including the data-driver for the analog circuit simulation. The pixel circuits are described as a diode-connected TFT. The parasitic

capacitance and resistance on the data-line are actually distributed parameters. Then the pixels are thought to have different effect depending on how far the pixel located from the driver. Therefore, we estimated the transient current at three position, so that, near-, middle- and far-pixels as shown in Fig. 3.

To accelerate the programming speed, we added the negative capacitance circuit represented as a symbol of  $-C_n$  in Fig. 3. Since the negative capacitance does not exist as a real device, this device was emulated by the semiconductor circuit which can be implemented in LSI. Figure 4 shows one example of the concrete circuit to achieve the negative capacitance. The value of negative capacitance is given by the following equation;

$$C_n = C_0 \frac{R_0 R_2}{R_1 R_3} \tag{1}$$

This negative capacitance circuit has the only current-source function. To provide the current-sink function, the complementary circuit using n-channel FET must be added. In case of the current-source driver, however, the current-sink function is not necessary if the data-line is reset with the sufficient low voltage at the beginning of each selecting period by n-channel transistor.

Assuming no resistance on the data-line, it is clear that the condition of  $C_n=C_p$  gives the shortest programming time. But considering the resistance, the conditions are complicated and dependent on the position of the pixel. If the condition varies so sensitively to the position, the parameters appearing in Eq.(1) must be changed with scanning the pixel. In non-sensitive case, the parameters can be fixed.

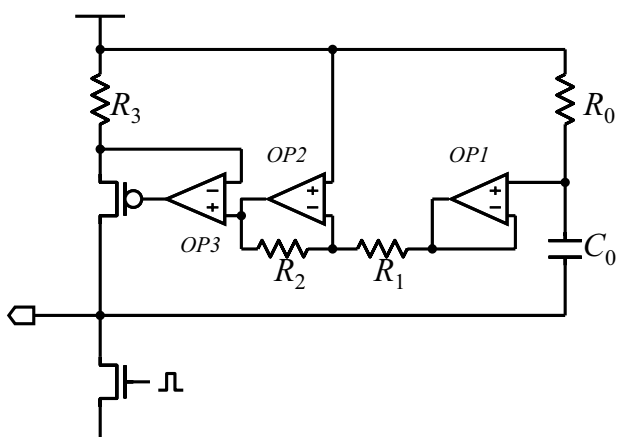
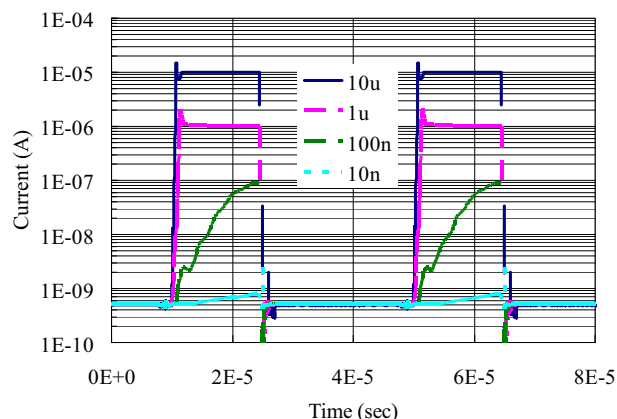
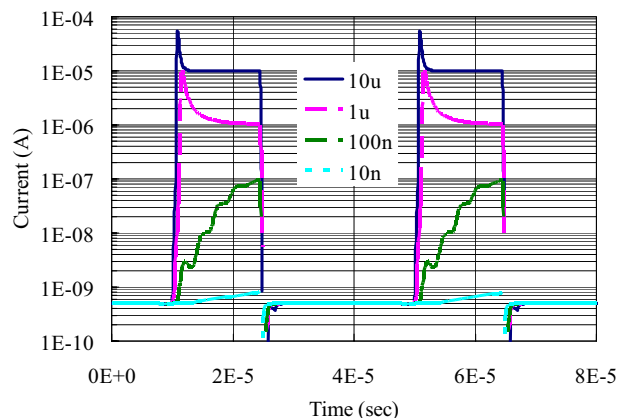

Fig. 4. Emulated circuit for the negative capacitance circuit.

### 4. Simulation results



(a) Near pixel



(b) Middle pixel

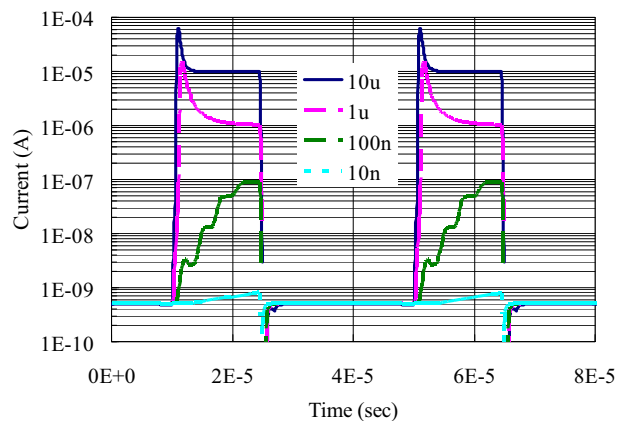

(c) Far pixel

Fig. 5. Simulated transient currents in programming period depending on pixel position.

Figure 5 shows the transient currents through the pixel circuit during the programming periods simulated under the conditions listed in Table 1.

**Table 1. Simulation parameters**

$R_p$	10k $\Omega$	$R_0$	100k $\Omega$
$C_p$	50pF	$R_1$	2.1k $\Omega$
$C_s$	1pF	$R_2$	21k $\Omega$
$C_0$	0.51pF	$R_3$	10.0k $\Omega$

The current-pulse width corresponding to the selecting period for  $I_{data}$  was settled to the 15 $\mu$ sec which corresponding to the full HD scanning time at the frame frequency of 60Hz. The current-pulse height was varied from 10nA to 10 $\mu$ A. The negative capacitance value was settled to 51pF according to Eq.1. This value is equal to the sum of  $C_p$  and  $C_s$ .

For the near pixel, the simulated transient currents reached to the setting current levels within the 15  $\mu$ sec for the setting current level more than 100nA. This pixel is located in the most optimal position since there is little deviation between the voltages at the negative capacitance and the pixel. The overshoot phenomena observed in the setting current levels at 10 $\mu$ A and 1 $\mu$ A were much small comparing with those of the other pixels. In the small current level, the setting time is very sensitive to the frequency response characteristics of the negative capacitance circuit. If the high-frequency characteristics are improved, the setting time can also be improved even at the low setting current level, but the overshoot phenomena in high setting current levels are enhanced and some resonances in a low setting current level easily occurs.

The transient currents in the middle and far pixels have larger overshoot phenomena than that of near pixel but the setting times in 100nA are almost the same as that of near pixel. The increase of overshoot would be due to the increase of CR delay on the data-line. The CR delay leads too large feedback signal.

In the small setting current levels, the behaviors of transient currents have small difference, that is, the behaviors are independent of the position of pixel. The resistance of data-line does not affect so much the behavior of transient current in a small data-current level because the IR drop gets smaller in small current levels.

## 5. Summary

The analog circuit simulation indicates that the negative capacitance feedback method can effectively shorten the current-setting time of current-programmed pixel compensation method less than 15 $\mu$ sec which corresponds to a full HD scanning time at the frame frequency of 60Hz. Even in the small programming current level such as 100nA, the current programming can be done within 15 $\mu$ sec, which is independent of the position of pixel.

## 6. References

1. T. Sasaoka, M. Sekiya, A. Yumoto, J. Yamada, T. Hirano, Y. Iwase, T. Yamada, T. Ishibashi, T. Mori, M. Asano, S. Tamura and T. Urabe, *SID'01 Technical Digest*, p.387 (2001).
2. J. H. Lee, W. J. Nam, K. C. Moon, M. K. Han, *Proceedings of IDW'02*, p.1393 (2002).
3. Y. W. Kim, O. K. Kwon, K. N. Kim, D. Y. Shin, B. H. Kim, H. K. Chung, *Proceedings of IDW'02*, p.367 (2002).
4. T. Shirasaki, T. Ozaki, K. Sato, M. Kumagai, M. Takei, T. Toyama, S. Shimoda, T. Tano, R. Hattori, *SID'04 Technical Digest*, p.1516 (2004).
5. S. J. Ashtiani, A. Nathan, *J. Display Technol.*, vol. 2, no. 2, p.258, (2006).
6. H. J. In, I. H. Jeong, J. S. Kang, and O. K. Kwon, *SID'05 Technical Digest*, p.252 (2005).
7. G. R. Chaji, A. Nathan, *J. Display Technol.*, vol. 1, no. 2, p.283, (2005).
8. C. H. Shim, R. Hattori, *Proceeding of IDW'07*, p.1985 (2007)
9. C. H. Shim, R. Hattori, *SID'08 Technical Digest*, p.105, (2008).
10. T. Shirasaki, T. Ozaki, T. Toyama, M. Takei, M. Kumagai, K. Sato, S. Shimoda, T. Tano, K. Yamamoto, K. Morimoto, J. Ogura and R. Hattori, *Proceeding of IDW'04* p.274 (2004)